



## PUMP MOTOR

12-24-48-72-80V ~ 3.0-4.0-6.0-8.0KW

24volt ~ 4100W ~ 2150rpm ~ Flange GR2 60X60  
isolation class "H" ~ CWDE ~ S2 27min

*heavy duty pump-motor  
powered with 8 brushes  
isolation class "H" IP 21  
2 x terminals of M10  
thermal protection 110°*



AM 102400

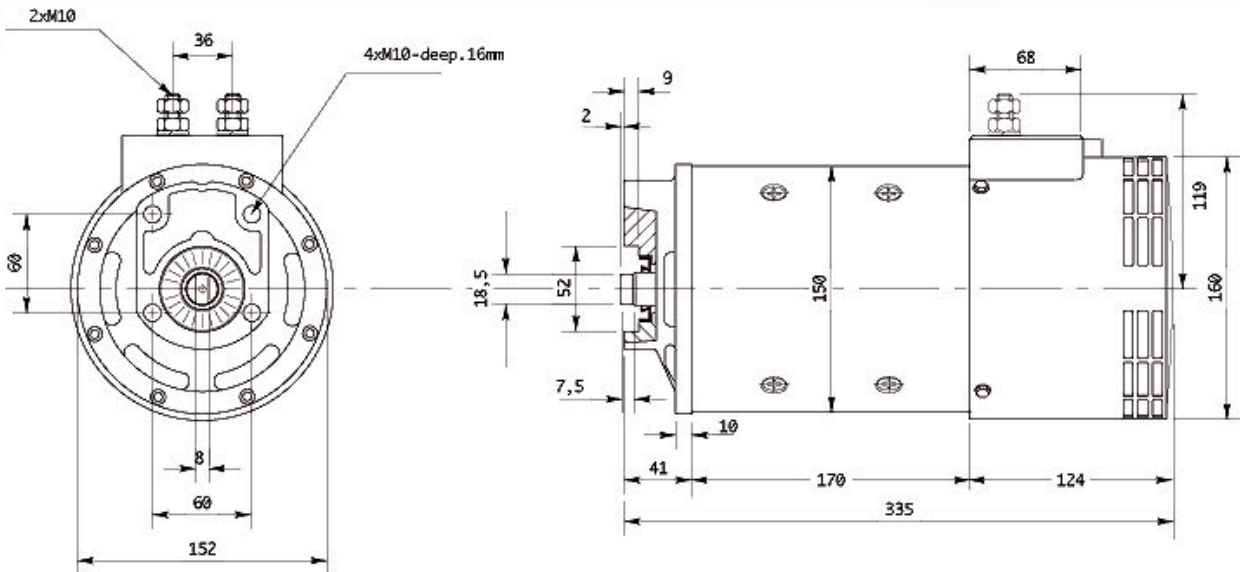

Address : Industrieweg 41a , 2382NT - Zoeterwoude  
tel.: +31(0)71 5811060 fax: +31(0)71 5811063  
www.bluetraction.eu info@bluetraction.eu